

# City of Tulare Building Division

411 E Kern Avenue, Tulare CA 93274 (559) 684-4218

## STANDARD PATIO PLAN

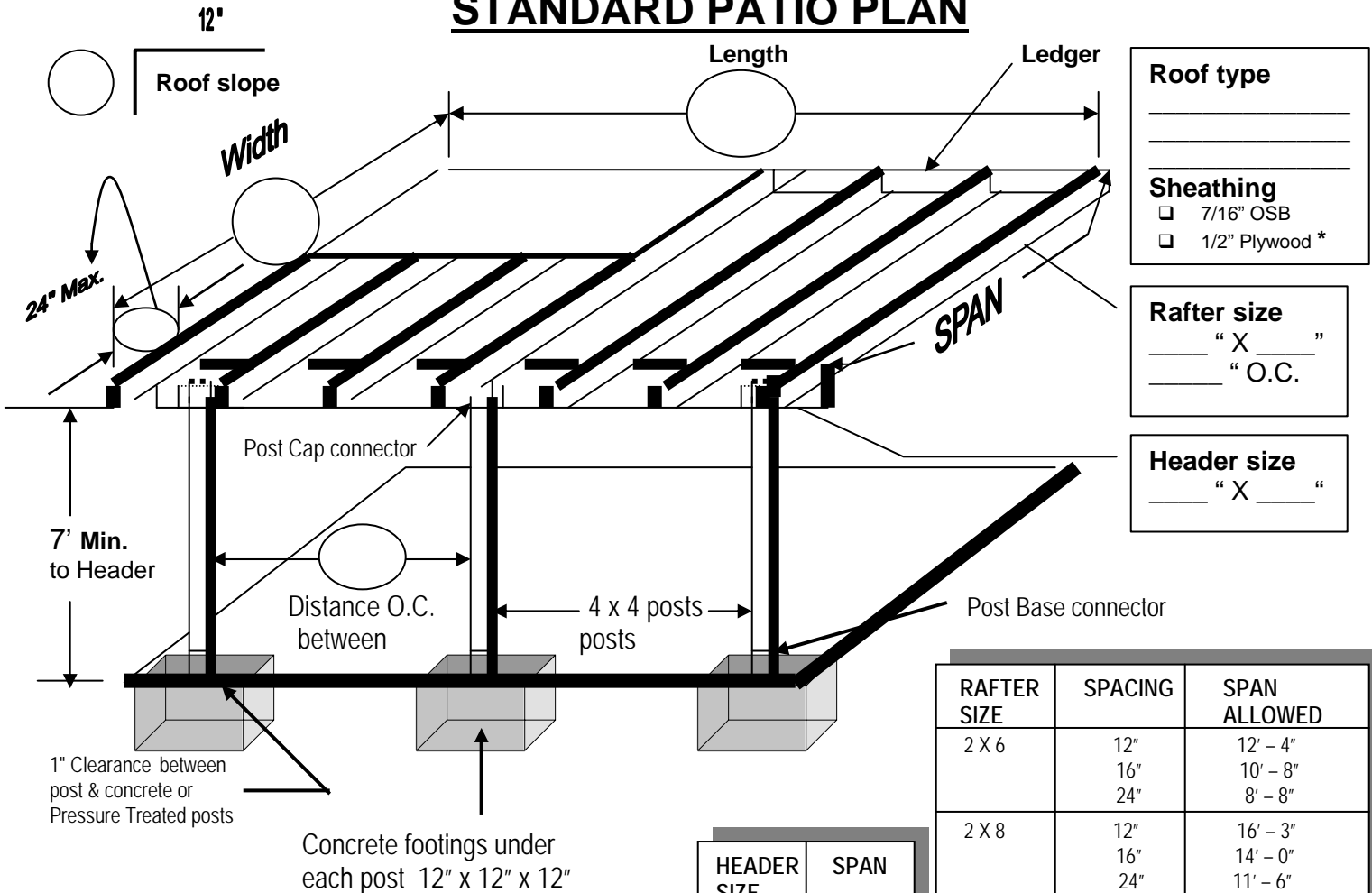

**Roof type**  
\_\_\_\_\_  
\_\_\_\_\_

**Sheathing**  
 7/16" OSB  
 1/2" Plywood \*

**Rafter size**  
 \_\_\_\_\_ " X \_\_\_\_\_"  
 \_\_\_\_\_ " O.C.

**Header size**  
 \_\_\_\_\_ " X \_\_\_\_\_"

RAFTER SIZE	SPACING	SPAN ALLOWED
2 X 6	12"	12' - 4"
	16"	10' - 8"
	24"	8' - 8"
2 X 8	12"	16' - 3"
	16"	14' - 0"
	24"	11' - 6"
2 X 10	12"	20' - 8"
	16"	17' - 11"
	24"	14' - 8"
2 X 12	12"	25' - 2"
	16"	21' - 9"
	24"	17' - 9"

HEADER SIZE	SPAN
4 X 6	6 FT.
4 X 8	8 FT.
4 X 10	10 FT.
4 X 12	12 FT.

### Approved methods of attachments Check one

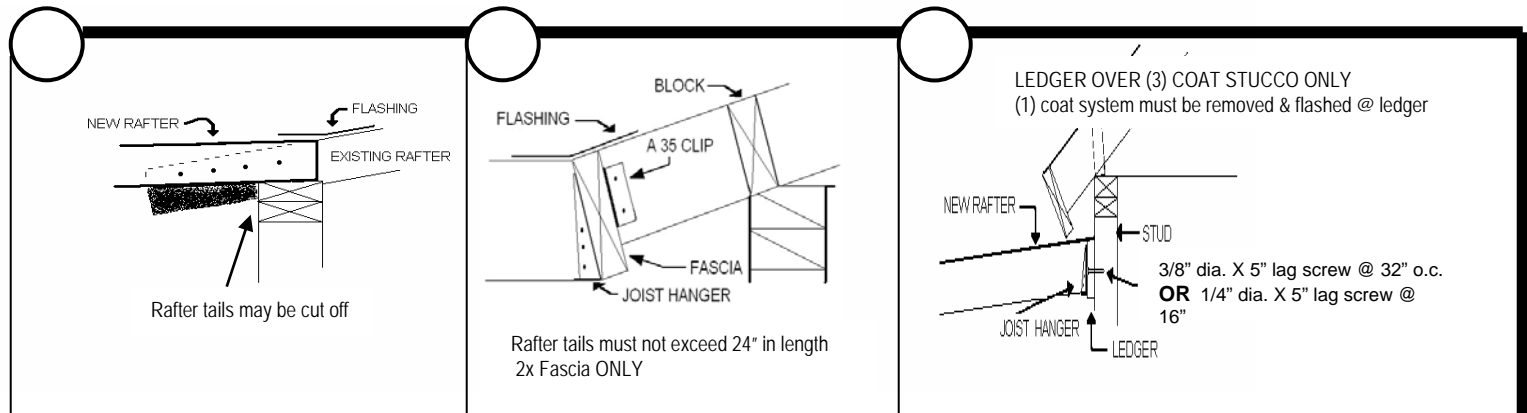

This design not approved to be enclosed.  
\* Exposed plywood shall be CCX or better.